

By L. B. Cebik, W4RNL

# Basic Beams for 12 and 17 Meters

Have you been looking for some well-designed and easy-to-build radiators for the 12- and 17-meter bands? Try these!

**S**mall directional beams are a popular choice for 12 and 17 meters. There, the lower signal density requires less gain and front-to-back ratio (F/B) than we need on other HF bands for successful operation. Although we can scale and adapt beams for 15 and 10 meters and press them into duty for 12 and 17 meters, we might save a bit of tower space and trouble by looking at alternative designs suited to these narrow bands.

## The Driver-Director Alternative

The most common form of two-element Yagi used on 20 through 10 meters is the driver-reflector type. The antenna offers modest gain and F/B with an easily matched feedpoint impedance. In a fairly straightforward way, we can design driver-reflector Yagis to cover the entire span of 20 and 15 meters and at least the first megahertz of 10 meters.

An alternative and much neglected two-element Yagi design uses a driver and a single director. On 20, 15 and 10 meters, this beam type is used only by those who wish to operate solely in either the CW (or data) or the SSB portions of the band. Driver-director Yagis are inherently narrow-band arrays that sustain their characteristics for a bandwidth that is less than 1% of the design frequency.

However, driver-director arrays have some advantages. [Figure 1](#) shows one of them: a shorter boom length. As we reduce the element spacing, the gain of driver-director Yagis increases (up to a limit). The feedpoint impedance also decreases with closer spacing. A practical spacing limit is between 0.07 and 0.08λ, leav-

ing us with a feedpoint impedance in the 20- to 25-Ω range. This impedance range minimizes power losses due to natural assembly resistances and lets us use standard matching networks, such as the gamma or beta. In contrast, a driver-reflector Yagi requires an element spacing between 0.125 and 0.15λ to optimize most parameters. In short, a driver-reflector Yagi will be 1.5 to 2 times longer than a comparable driver-director design.

The driver-director design offers a second benefit over the driver-reflector Yagi: increased F/B. [Figure 2](#) overlays free-space azimuth patterns for the two designs for 17 meters. With respect to gain, there is little difference between the designs, with the driver-director array having a slight, but not operationally significant, advantage. In the F/B department, however, the driver-director array shows nearly a 10-dB improvement.

The so-called “WARC” bands (30, 17, and 12 meters) are very narrow, with 17 and 12 being 100 kHz wide (18.068 to 18.168 MHz and 24.89 to 24.99 MHz, respectively). These bandwidths fall well within the operating bandwidth limits of driver-director Yagis. Driver-director Yagis may be very well suited for these bands, with performance improvements over other designs and savings in boom length and wind loading.

## Monoband Beams for 12 and 17 Meters

I designed a pair of driver-director Yagis for 12 and 17 meters using antenna-modeling software, in this case, *NEC-4*.<sup>1</sup> *MININEC* and *NEC-2* would have been equally satisfactory. My procedure involved two steps: creating a basic design with a uniform-diameter

<sup>1</sup>Notes appear on [page 62](#).

**Table 1**  
**Basic (Uniform-Diameter) Element Dimensions for 17- and 12-Meter Driver-Director Yagis**

All dimensions are in inches.

### 17 Meters: 0.5-Inch-Diameter Elements

Driver Length	314.4
Director Length	304.6
Element Spacing	49.6

### Beta (Shorted Transmission Line) Length

Impedance	Length
600 Ω	6.6
450 Ω	8.8

### 12 Meters: 0.5-Inch-Diameter Elements

Driver Length	228.0
Director Length	221.3
Element Spacing	36

### Beta (Shorted Transmission Line) Length

Impedance	Length
600 Ω	4.8
450 Ω	6.4

**Table 2**  
**Anticipated Performance Parameters: 17- and 12-Meter Driver-Director Yagis**

Frequency (MHz)	Free-Space Gain (dBi)	F/B (dB)	Pre-Match Feedpoint Impedance ( $R \pm jX$ Ohms)	Post-Match Feedpoint Impedance ( $R \pm jX$ Ohms)
-----------------	-----------------------	----------	--	---

### 17 Meters

18.068	6.3	20.6	21 - j30	60 + j16
18.118	6.5	21.9	20 - j27	55 + j6
18.168	6.7	20.8	18 - j23	46 - j3

### 12 Meters

24.89	6.5	21.7	19 - j29	62 + j10
24.94	6.6	21.6	18 - j26	56 + j2
24.99	6.7	20.2	17 - j24	49 - j4

Note: When remodeling for an element taper schedule, adjust element lengths to achieve these performance figures.

model and then adjusting the dimensions for the use of an “element-taper schedule.” An element-taper schedule specifies in decreasing sizes the tubing diameter used for each element from the center to the tip. At HF, uniform-diameter elements add unnecessary weight to the antenna. Moreover, available nesting aluminum tubing sizes (I recommend 6063-T832) make construction convenient.

Table 1 presents the dimensions of the basic uniform-diameter models, using 0.5-inch-diameter elements. The dimensions for each antenna are set so that the driver shows a reactance of about  $-j25 \Omega$ . This reactance facilitates the use of a beta match hairpin, which is actually a shorted section of transmission line and provides an inductive reactance across the feedpoint connections. The table lists alternative lengths according to the impedance of the parallel line fabricated for the beta line.

The anticipated performance as predicted by the NEC models appears in Table 2. We can expect a free-space gain of about 6.5 dBi, with a F/B ratio of over 20 dB. I have listed the anticipated pre-matched and post-matched feedpoint impedances for both antennas. In the NEC models, the beta match consists of a shorted transmission line placed in parallel with the feedpoint.

One error often made by beginning antenna builders is to simply copy model dimensions using whatever materials may be available. This route often leads to mediocre beam performance. Before we translate the model into a physical antenna, we must adjust the dimensions for the element-taper schedule.

Figure 3 shows the taper schedule used in the test antennas. The centermost section uses 36 inches of  $3/8$ -inch-diameter tubing, starting from the element centerline. The next tubing section is a 6-foot length of  $1/2$ -inch-diameter material, with 69 inches showing. The overlap is about 3 inches: much more overlap adds unnecessary weight, while much less weakens the junction. The element tip sections are made from  $3/8$ -inch-diameter tubing. The 12-meter tips are quite short, while the 17-meter tips are quite long.

The element lengths and tip sections are listed in Table 3. The taper schedule used here is for test purposes only. Although the final elements appear to be strong, many builders prefer to use a more aggressive taper schedule for additional strength. That is to say, they use more different tubing sizes, beginning with a larger diameter. This technique results in shorter lengths of each tubing size, a practice that can yield stronger elements. Part of my reason for using longer lengths of fewer tubing size stems from a desire to reuse the tubing in other test antennas.

If we keep the same spacing as we used with the uniform-diameter model, the element lengths for the tapered elements will be longer to achieve the same performance and feedpoint impedance. On 12 meters, the elements will be four to six inches longer than on the uniform-diameter model. On 17 meters, the elements will be over six inches longer on the tapered-element model.

If we choose a more aggressive tapering schedule, we may expect the elements to be even longer relative to the uniform diameter model. This holds true even if we begin with larger-diameter

tubing. The required extra length to make a tapered-diameter element electrically equivalent to a uniform-diameter element is not simply a function of the average diameter. Instead, it is a complex function involving the tubing diameters and the rate of decrease along the element length.<sup>2</sup> In general, for any beam you wish to

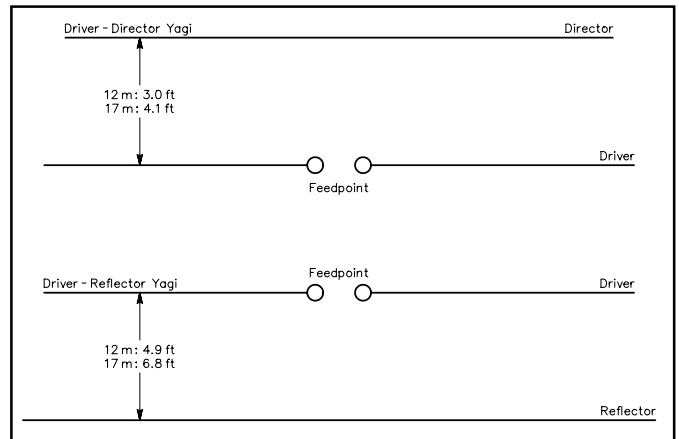

Figure 1—A comparison of driver-reflector and driver-director types of two-element Yagi arrays.

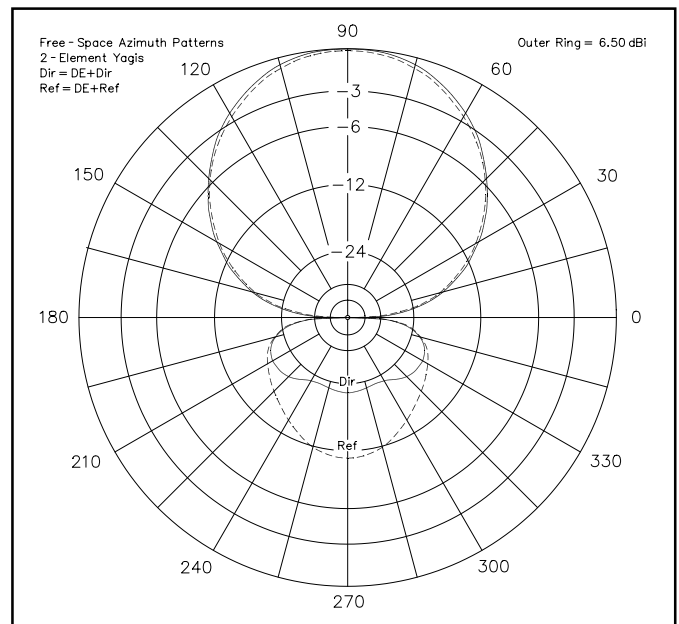

Figure 2—Overlaid free-space azimuth patterns of 17-meter two-element driver-director and driver-reflector arrays.

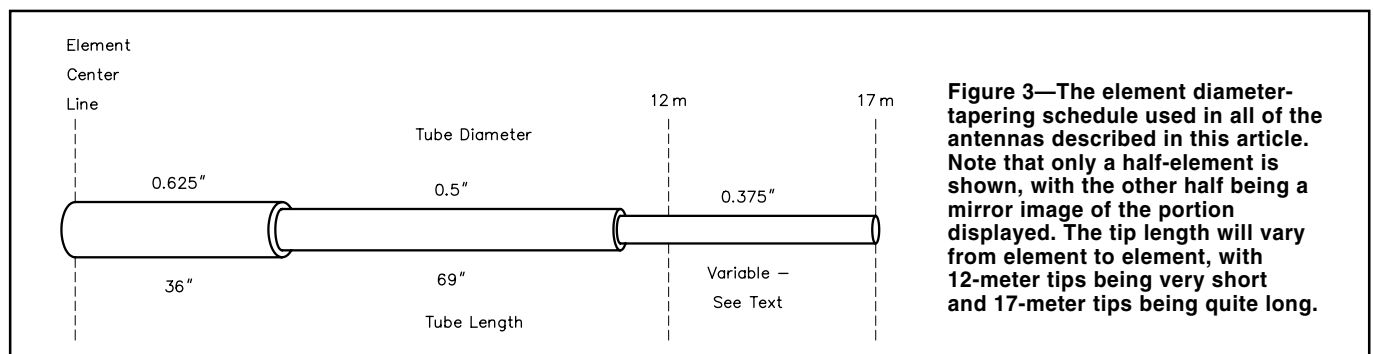

Figure 3—The element diameter-tapering schedule used in all of the antennas described in this article. Note that only a half-element is shown, with the other half being a mirror image of the portion displayed. The tip length will vary from element to element, with 12-meter tips being very short and 17-meter tips being quite long.

reproduce using a variant tapering schedule for the elements, it pays to remodel the antenna using the materials planned for the physical version. Modeling software, whether devoted strictly to Yagis or more generally applicable (such as *NEC*), provides the best known guidance for Yagi construction. In many cases, I have built Yagis directly from careful models and have had to make either no adjustments or only the most minimal adjustments.

In the case of the 12- and 17-meter band driver-director Yagis, the only required adjustment made was to the beta-match shorted line. My test line consisted of #12 AWG copper wire spaced as close

as possible to one inch. The match-line spacing was dictated by the spacing of the stainless-steel bolts on the driver used for both the beta and the female coax connection. Because the characteristic impedance of a one-inch-spaced #12 line is close to 385  $\Omega$ , the line length increased slightly from the *NEC* model: to a little over 10 inches on 17 meters and to a little over 7 inches for 12 meters.

My test models used polycarbonate (Lexan) plates to mount the elements to the boom. Figure 4 is a close-up of the driver boom-to-element plate, with the coax connector and its connections before adding the beta match. There is no allowance in the models for “plumber’s delight” construction in which the elements make electrical contact with the boom. For short-boom antennas, I often use either PVC or aluminum tubing as the boom and have found no difference for these antennas when using insulated elements. Figure 5 shows the 12-meter version of the antenna during initial construction, using a four-legged support stand to bring all of the antenna components to a good working level.

Field adjustment of the antennas is a two-step procedure. After verifying that the element structures and spacing correspond to the model, use one of the available SWR analyzers to read both the feedpoint resistance and reactance without the beta match line. The readings should correspond closely to the model reports. If not, then adjust the elements until they do. This should involve no more than a small change of the driver tip lengths. A driver-director Yagi is just a bit more finicky than a driver-reflector beam in driver length adjustment, but mounting the antenna on a long mast and propping it on a stepladder can ease the task. Position the antenna to point upward as straight as possible and get it as high off the ground as you can while still being able to reach the driver for adjustment. Although the result may not hold precisely when the antenna is at its operating height, the setting will generally be close enough to permit final adjustment only to the beta-section length or width, since widening the beta match is equivalent to increasing its length.

Now, at near-ground level, add the beta match and adjust its size for a nearly perfect 50- $\Omega$  match at the center of the band. Secure the connections. At the antenna’s operational height, you should be able to refine the adjustment with nothing more complex than a little widening or narrowing of the line.

I have omitted other building details, since there are so many preferred variations.<sup>3</sup> My element-to-plate U bolts are stainless steel and use saddles, as do the plate-to-boom U bolts. The driver has an 18-inch-long insert of 1/2-inch-diameter Fibreglas rod that aligns the split element sections and prevents tube crushing from either the U bolts or the connection bolts. I use a 1/4-inch-thick aluminum plate for the boom-to-mast mounting, with U bolts sized for the mast and the boom. Tubing sections can be locked together with stainless-steel hose clamps, aircraft-grade pop rivets, or sheet-metal screws. Deburr drilled holes to ensure that you can separate the element sections later in the life of the beam. In addition, a thin coating of a conductive antioxidant at each tubing junction is advisable.

### Two Beams in One

The individual two-element Yagis for 12 and 17 meters can be stacked on a single mast and fed individually. However, the two antennas tend to interact, even with a separation of up to 12 feet. The 17-meter Yagi will show a small increase in gain, but a larger (5-dB) decrease in F/B at some separations. The 12-meter beam shows a reduction in gain with an increase in the feedpoint impedance (with the beta line installed). A separation of about 8 feet appears to be as close to optimal as you might get.

Even though the individual antennas are lightweight, many builders prefer to have their beams lined up in one plane. Therefore, finding a way to combine two beams in a single dual-band array appears desirable. At the same time, if we can reduce the number of feed lines to one, we will have simplified everything possible.

One of the simplest techniques for feeding two beams with a

PHOTOS BY THE AUTHOR

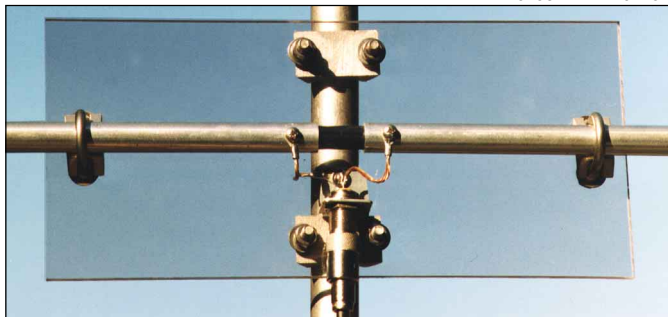

**Figure 4**—A close-up view of the polycarbonate boom-to-element plate, saddle U bolts, Fibreglas stiffening rod, and driver connection points of the beams in this article. The construction of parasitic elements is similar, but the element is continuous across the plate.

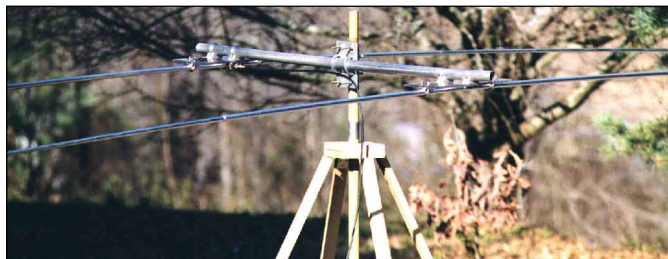

**Figure 5**—The 12-meter driver-director beam during initial construction, using a stand and short mast to raise the elements to a good working height.

**Table 3**  
**Adjusted Stepped-Diameter Element Dimensions for 17- and 12-Meter Driver-Director Yagis**  
All measurements are in inches.

#### 17 Meters

Driver Length	321.4	Tip Length	55.7
Director Length	311.4	Tip Length	50.7
Element Spacing	49.6		
Beta (shorted transmission) line length (1-inch-spaced #12 AWG wire)	10.3		

#### 12 Meters

Driver Length	231.6	Tip Length	10.8
Director Length	224.6	Tip Length	7.3
Element Spacing	36		
Beta (shorted transmission) line length (1-inch-spaced #12 AWG wire)	7.3		

See the text and [Figure 3](#) for the element-tapering schedule used for this example. Final dimensions may vary with changes in the element-tapering schedule.

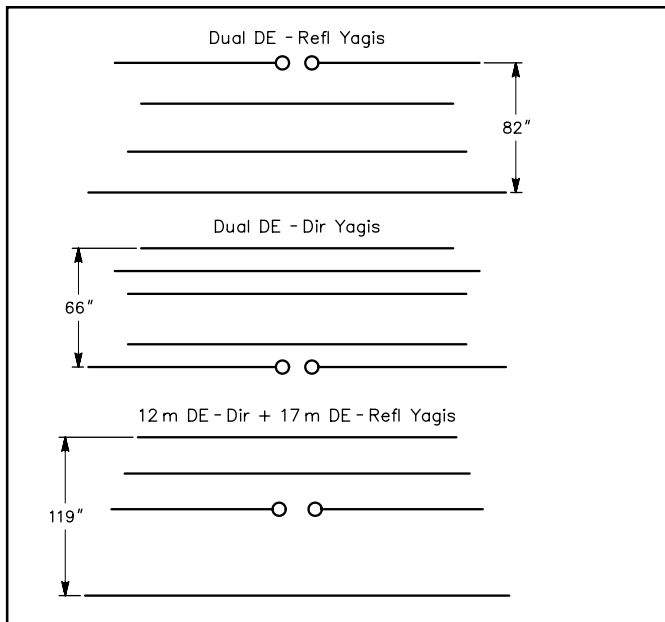

**Figure 6—Outline drawings of some possibilities for open-sleeve coupled 12- and 17-meter arrays. See the text for the reasons why the top two have been rejected for this article, even though they might be capable of good performance.**

single line is to use open-sleeve coupling, a technique developed and patented by Tom Schiller, N6BT. In effect, we connect the feed line to the lower-frequency driver. On the lower band, the driver acts normally as part of its array of elements. On the higher band (or bands, in the case of triband beams), we simply feed the lower-frequency driver with the higher-frequency signal. Closely spaced to the lower-band “master” driver is a shorter “slaved” driver for the upper band. It receives virtually all of the higher-frequency energy and operates as the driver for its own array of elements.

Finding the correct length and spacing for the slaved driver can be tedious without some guidance. The object is to adjust the length and spacing so that the master driver shows the proper feedpoint impedance at not only its own lower frequency, but at the higher frequency as well.

Assuming we want to have both beams pointed in the same direction, there are several approaches to combining the two beams using open-sleeve driver coupling. Three such approaches are outlined in Figure 6. One scheme, at the upper left, combines two driver-reflector Yagis, with the 12-meter elements nestled inside the 17-meter pair. A second scheme, at the upper right, combines driver-director Yagis, with the 12-meter driver immediately in front of the 17-meter driver. Note that the 12-meter beam has three elements. When a higher-frequency director lies behind or in front of a director used for a lower frequency, it tends to yield poor results. The answer is to use two directors. Although the single director will not yield standard two-element (driver-director) performance, the pair of directors does. The inner and outer director combination yields standard two-element performance—and sometimes a little bit more.

However, I have rejected both of these schemes for the present effort, although either one would produce a very compact dual-band Yagi. Both designs are very finicky. Models indicate that adjustments of less than a quarter inch in either element length or spacing for the 12-meter drivers can upset performance. Although such tolerances can be obtained in a commercially produced beam, home construction rarely permits such precision.

Less critical is the lower scheme in Figure 6. This array uses a driver-reflector design for 17 meters with a driver-director design for 12 meters. The overall length is about 10 feet, with the master

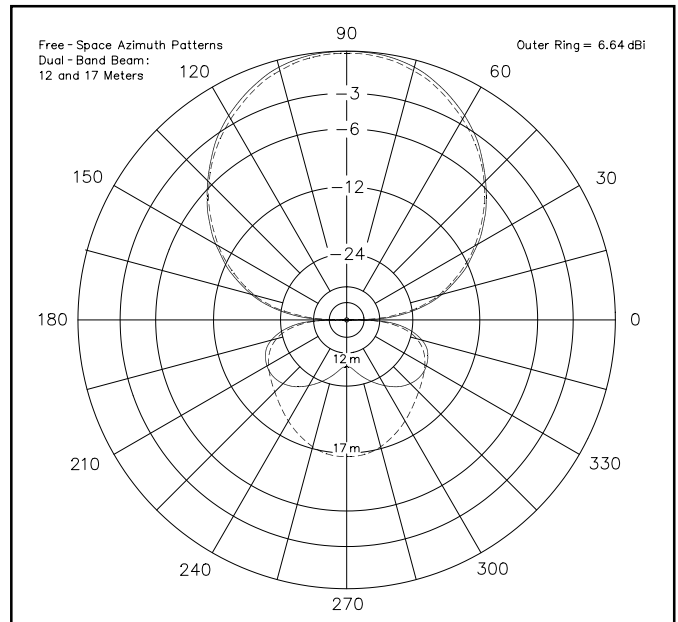

**Figure 7—Overlaid 12- and 17-meter free-space azimuth patterns for the dual-band beam described. Compare these patterns to those in Figure 2.**

**Table 4**

**Basic (Uniform-Diameter) Element Dimensions for a 17- and 12-Meter Dual-Band Yagi**

All measurements are in inches.

Element	Function	Length	Distance from Reflector
1	17-m Reflector	326.4	—
2	17-m Driver (fed)	307.2	81.6
3	12-m Driver (slaved)	234	85.9
4	12-m Director	222	119.2

driver positioned just forward of the center of balance, where the boom-to-mast mounting plate attaches. The design has an added advantage. We can select any desired impedance for the upper-band beam simply by changing the spacing and length of the slaved driver until the master driver shows the desired impedance with a 12-meter signal. With a driver-reflector beam for 17 meters, we can choose element spacing that gives us an acceptable match when directly connected to 50-Ω coaxial cable. With proper design, we can forget a matching network altogether.

As we did for the individual beams, let’s design the dual-band beam a step at a time. The first step is to design it with uniform-diameter elements. Table 4 shows the resulting dimensions for the combination array. Note that the 12-meter driver is spaced from the 17-meter driver by 4.3 inches. This distance is close enough to worry any antenna designer using *NEC* software, because *NEC* has a known problem with closely spaced wires of different lengths. So I ran the problem on *MININEC* as well. It indicated that the slaved 12-meter driver needed to be about one inch shorter and a quarter-inch closer to the master driver than the *NEC* numbers in the table. This is one of several clues we shall later use to field-adjust the beam to perfection.

In good designs using open-sleeve coupling, the upper-band elements have virtually no effect on the impedance for lower-band signals. Hence, once the lower-band elements are set, they require no change as we adjust the upper-band elements. Unfortunately,



**Table 5**  
**Anticipated Performance Parameters: 17- and 12-Meter Dual-Band Yagi**

Frequency (MHz)	Free-Space Gain (dBi)	F/B (dB)	Feedpoint Impedance $R \pm jX$ (Ohms)
<b>17 Meters</b>			
18.068	6.5	11.3	43 + j2
18.118	6.4	11.4	46 + j6
18.168	6.3	11.5	49 + j8
<b>12 Meters</b>			
24.89	6.5	27.1	61 + j5
24.94	6.5	31.9	53 + j6
24.99	6.6	33.8	44 + j8

Note: When remodeling for an element taper schedule, adjust element lengths to achieve these performance figures.

**Table 6**  
**Adjusted Stepped-Diameter Element Dimensions for a 17- and 12-Meter Dual-Band Yagi (Two Versions)**

All measurements are in inches.

**Test-Model Taper Schedule**

Diameter	Length
0.625	36 (from element center)
0.5	69
0.375	tip (see below)

Element	Length	Tip Length	Distance from Reflector
1	334.0	62.0	—
2	313.8	51.9	81.6
3	239.0	14.5	85.9
4	225.4	7.7	119.2

**Alternative Taper Schedule**

Diameter	17-m Length	12-m Length
0.75	48 (from element center)	12 (from element center)
0.625	33	18
0.5	33	48
0.375	Tip (see below)	Tip (see below)

Element Number	Element Length	Tip Length	Distance from Reflector
1	338.4	55.2	—
2	314.4	43.2	81.6
3	241.7	42.8	86.2
4	228.0	36.0	119.2

the rejected schemes did require some changes in the lower-band element lengths, which then required some readjustment of the upper-band lengths—another daunting aspect of their demands for the home builder. The design in Table 4 is quite stable, and adjusting the 12-meter elements leaves the 17-meter elements unaffected.

Table 5 shows the modeled performance of the antenna in free space. Especially important is the column of feedpoint impedance numbers. The spacing of the 17-meter elements was selected as a compromise between obtaining the highest gain for this type of two-element Yagi and having a low 50-Ω SWR. On 12 meters, the impedance magnitude changes direction relative to the 17-meter progression as we raise frequency. In addition, the rate of change is much more rapid. The fast impedance change presents a major challenge to commercial antennas using this feeding technique for 20, 15 and 10-meter Yagis. However, for 17- and 12-meter use, the amount of change is well within tolerances for a good 50-Ω match. All we need to add at the feedpoint is a standard 1:1 choke balun,

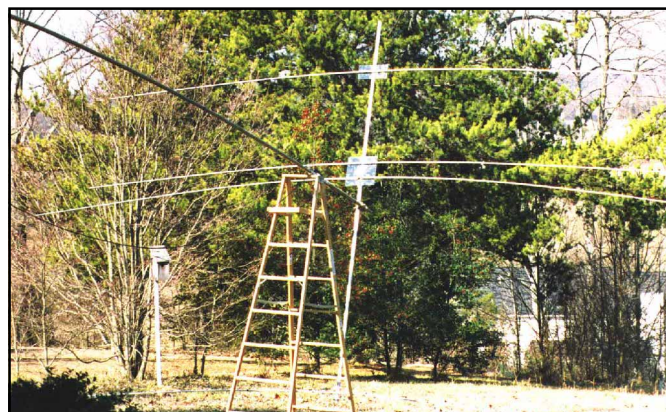

**Figure 8—The dual-band beam during mounting to a crank-up mast fixture used at W4RNL for initial testing and adjustment of small arrays. See the text for a technique to keep the two driver elements parallel to each other.**

which can be a coil of coax or a ferrite-bead balun of W2DU design. This precaution suppresses common-mode currents on the feed line.

Because this design uses a reflector for the lower band, we see a distinct difference in the F/B for the two bands. Figure 7 provides the same information in more graphic form by overlaying the azimuth patterns for the two bands. Although not operationally significant, the 17-meter driver-reflector combination has a modicum more gain and better F/B than the beam might have if used independently. The shorter 12-meter elements have a slight director function on 17 meters. Likewise, the 17-meter elements function (although minimally) as reflectors on 12 meters, elevating the F/B on that band relative to the use of the 12-meter elements as an independent beam. The phenomenon has acquired the name “forward stagger,” indicating the design principle of placing higher-band elements forward of lower-band elements for best performance.

We are now ready to translate our basic design into a practical one that uses stepped-diameter tubing for the elements. The test model used the same tapering schedule as the independent beams—because it used the same elements with only the tips adjusted. Table 6 gives the required overall element lengths and the tip lengths for each of the elements in the final array.

To quickly illustrate that changing the tapering schedule may also change the element lengths, the table also identifies a second version of the beam. This version has the same modeled performance as the basic and the test models. However, it uses a more aggressive tapering schedule. It begins with 3/4-inch diameter tubing and progresses to 3/8-inch-diameter tubing. The progressions differ for the two bands to yield the strongest elements of each overall length. Note that the required element lengths are all longer than those for the test model, despite the fact that the center element sections have a larger diameter than those of the test model. Moreover, the NEC model indicates that the driver spacing should be slightly greater, although field adjustment determines the final spacing.

**Construction and Adjustment of the Dual-Band Beam**

Construction of the test antenna is simply a doubling of the element mounting tasks described for the monoband driver-director Yagis. If element-mounting plates are used for the two drivers, the plate edges that face each other should be trimmed so that driver spacing can be adjusted to its final value. Because the spacing (depending on the element sizes used) may be less than four inches center-to-center, the plates should extend no more than two inches from the element centers. For 12 and 17 meters, metal or polycarbonate plates need not be more than about four inches wide for good mounting strength.

For this beam, cut and assemble the reflector, master driver and director to length. Then preposition and tighten these elements

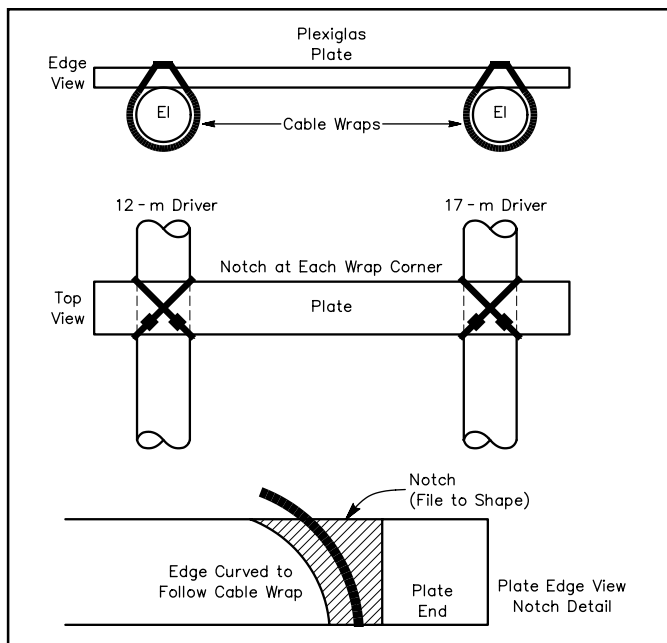

**Figure 9—Details of a simple master-slave driver alignment plate with cable-wrap binders.**

before installing the slaved driver. The slaved 12-meter driver is the only element that requires patient adjustment. Much of the work can be accomplished with the beam supported by a mast set horizontally so that the reflector is 5 to 10 feet off the ground and the beam is pointed straight up. Check the feedpoint impedance and double-check the element dimensions and spacing. If the feedpoint impedance is close to the modeled values and the beam passes the dimensional checks, then the 17-meter portion of the beam will perform up to the modeled standard. Figure 8 shows the entire two-band array during construction on a crank-up assembly that I use to make adjustments and tests.

Recheck the length and install the slaved driver, but don't lock down the tips or the spacing. Using the modeled spacing as the starting point, measure the feedpoint impedance on the master driver with a 24.94-MHz signal. You may find a resistance that is either higher or lower than the desired level and a reactance that may be either inductive or capacitive. The combination you discover dictates whether you will adjust either the spacing or the element length. Here is the guideline for this particular antenna:

1. Increasing the element length decreases the feedpoint resistance and makes the reactance more inductive (or less capacitive). Decreasing the element length does just the opposite, increasing the feedpoint resistance and making the reactance more capacitive (or less inductive).

2. Closing the spacing decreases the feedpoint resistance and makes the reactance more capacitive (or less inductive). Opening the spacing increases the resistance and makes the reactance more inductive (or less capacitive).

If this is your first open-sleeve coupled beam, be extra patient. It is easy to forget the guidelines and adjust the wrong parameter. If that happens and the feedpoint values appear to be going awry, return the slaved element to its original length and spacing and start the procedure again. Make very small changes between feedpoint measurements until you get a good feel for how much each increment of change affects the feedpoint impedance.

Once you have set the slaved driver to give a proper impedance or SWR curve on 12 meters, recheck the 17-meter feedpoint impedance. It should not have changed by an amount requiring readjustment of the element. Also, check the spacing between the slaved driver and the director. Set the spacing to within about a quarter

inch of the model to ensure good performance across the 12-meter band. Moving the driver up to an inch might dictate one more round of slight adjustments to the slaved driver for the best SWR curve.

These adjustments should hold when the antenna is raised to its operating height. However, recheck the feedpoint impedances on both bands to be certain.

Because the spacing between drivers is somewhat critical, you may experience some SWR fluctuations in gusty winds that push the two drivers back and forth. (The difference in element droop between the two drivers, shown in Figure 8, gives an indication of how the wind may also change the element spacing from a parallel set of lines.) You can minimize the fluctuations by locking the two drivers together with a simple Plexiglas or acrylic plate, as shown in Figure 9. The plate can be about an inch or so wide and long enough to allow about one-half inch of overhang past each driver. You can use material up to one-quarter inch thick, but one-eighth inch will normally work well. File notches into the plate so that crossed cable wraps lock the plate in place when tightened. The filing suggestion in the figure is a reminder to avoid a sharp edge where the cable tie bends across the plate. UV-resistant cable wraps are the most durable.

Place these plates about three to four feet from the element center on each side of the array. *Do not* lock the cable ties to the tubes with adhesive. It is important for the tubes to be free enough to move lengthwise in the clamps so that they are never overstressed by winds. The plates simply maintain the spacing between the drivers, forcing them to wobble in the wind in unison.

Like all beams, the dual-band array needs at least annual inspection and preventive maintenance. Check the feedpoint connections, the tubing junctions, all junction plates and hardware and the weather seals you place over coax connectors. While you are up on the tower, check the rotator and its connections as well. If you make your checks by lowering the beam, feel free to clean the tubing as well. Annual maintenance is also a good time to remove old bird and insect nests from any of the crevices they like to use.

## Summary

Relatively high performance is easy to obtain on 12 and 17 meters, where beams are light and inexpensive to build. These beams provide some of the highest performance available for their degree of complexity. They require a bit more patient adjustment than simple driver-reflector beams, but the size reductions and performance improvements may make the effort worthwhile.

## Notes

<sup>1</sup>NEC-4 is available in two commercial implementations: GNEC by Nittany Scientific and EZNEC Pro by Roy Lewallen, W7EL, PO Box 6658, Beaverton, OR 97007; tel 503-646-2885, fax 503-671-9046; [w7el@eznec.com](mailto:w7el@eznec.com); <http://www.eznec.com>. Nittany Scientific, Inc, 1733 West 12600 South, Suite 420, Riverton, UT 84065; [sales@nittany-scientific.com](mailto:sales@nittany-scientific.com); <http://www.nittany-scientific.com>. However, a license from the University of California is also required to use either of these programs. In contrast, NEC-2 and MININEC are public domain calculating cores with many commercial implementations.

<sup>2</sup>For a good treatment of tapered-diameter elements and their relationship to uniform-diameter elements, see David B. Leeson, W6QHS, *The Physical Design of Yagi Antennas* (Newington: ARRL, 1992), Chapter 8.

<sup>3</sup>For alternative methods of constructing beam antennas, see any recent edition of *The ARRL Antenna Book*.

*An ARRL Life Member and educational advisor, L. B. Cebik, W4RNL, recently retired from The University of Tennessee at Knoxville to pursue his interests in antenna research and education, much of which appears at his Web site (<http://www.cebik.com>). A ham for over 45 years, his articles have appeared in several League publications including QST, QEX, NCJ and The ARRL Antenna Compendium. You can contact L. B. at 1434 High Mesa Dr, Knoxville, TN 37938-4443; [cebik@utk.edu](mailto:cebik@utk.edu).*

1434 High Mesa Dr  
Knoxville, TN 37938-4443  
[cebik@utk.edu](mailto:cebik@utk.edu)

